



KTSE-1

**Features**

- Daisy Chain RXT transfer switches
- Eliminates need for RDT switch as slave switch
- Simple four wire hook-up. No cutting or splicing required
- Transfer switch control board plug, connects directly into the RXT Expander
- Packaged complete with all necessary components for a successful installation
- LED Indicator confirms utility or transfer mode
- Maintenance free, requires no batteries or adjustments
- RXT control board can be removed from slave transfer switches
- Small footprint that easily installs in transfer switch enclosure where control board was located
- One unit required for each slave switch being installed
- 5 Year Warranty
- It is highly recommended to install a surge protection device on the line side of the master switch



**ATTENTION: JUMPER MUST BE INSTALLED OR THE PRODUCT WARRANTY WILL BE VOIDED. (See Install Sheet)**

**Dimensions**

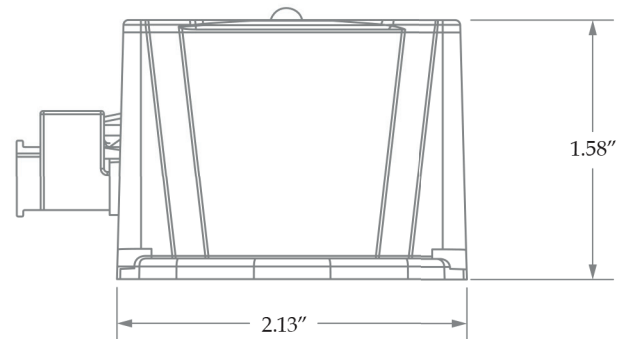
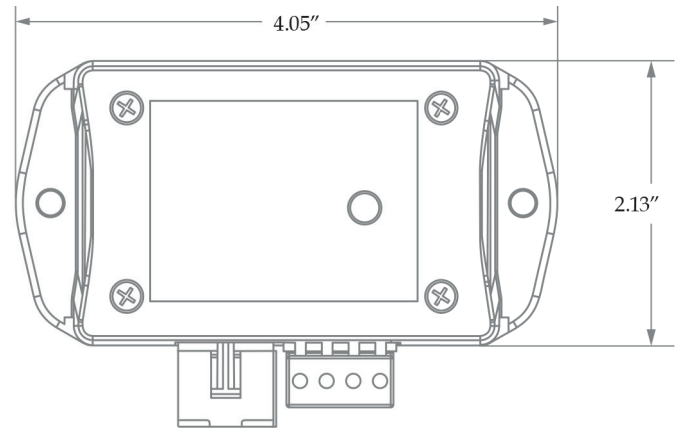
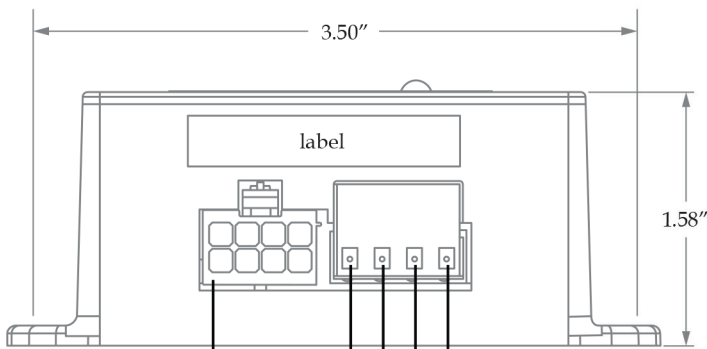

Unplug transfer switch control board plug and remove transfer switch board.  
Attach this device to the same location as the board removed.  
Plug up the control board plug.

Run these two wires to 12 Volts outputs out of the first transfer switch

Run these two wires to the leaf switch in the first transfer switch